

SONY



Intel® Centrino® Duo Processor Technology

VAIO FZ

VGN-FZ15G

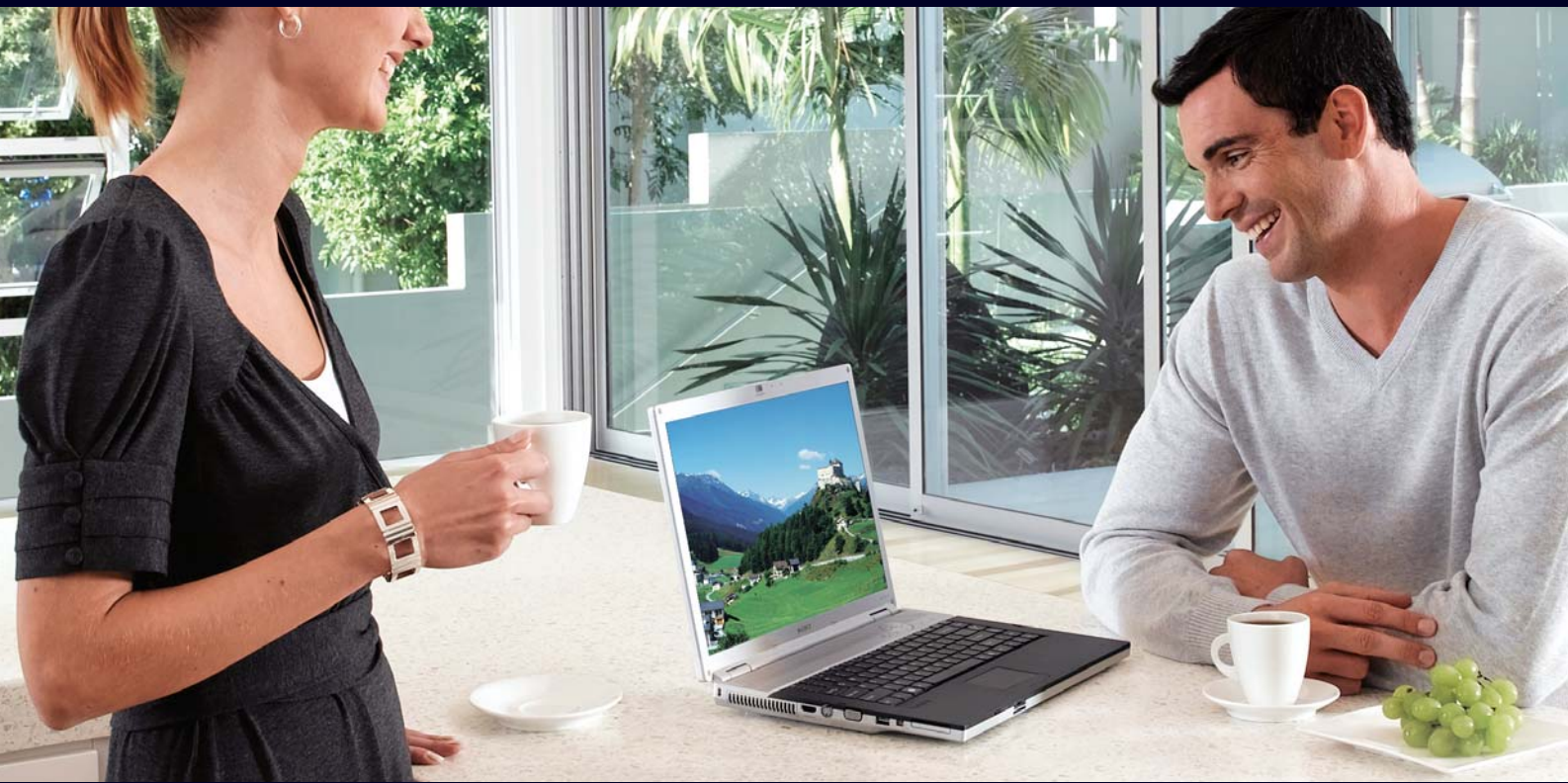

Brighten your day with style and ease



like.no.other

VAIO
no more bounds

Specifications

Model	VGN-FZ15G
Processor Technology	Intel® Centrino® Duo Processor Technology • Intel® Core™2 Duo Processor T7100 (1.80 GHz) ^{1,2} • Intel® PRO/Wireless 3945ABG Network Connection • Mobile Intel® PM965 Express Chipset
OS	Genuine Windows Vista™ Home Premium (English version) with Traditional Chinese Language Pack
Chipset	Mobile Intel® PM965 Express Chipset
Processor System Bus	800MHz
Memory Bus	667MHz
Cache Memory	2MB Advanced Smart Cache
Main Memory	1GB ³ (upgradeable up to 2GB)
SO-DIMM slots	2 SO-DIMM slots (The pre-installed memory module uses one)
Hard Disk Drive	120GB (HDD recovery storage max: 8GB ⁴ , C: Remain) Serial ATA, 5400rpm
Drive	DVD±RW/±R DL/RAM Drive
Optical Disc Drive	Maximum Reading Speed DVD+R: 8x (Single Layer), 6x (Double Layer) / DVD-R: 8x (Single Layer), 6x (Dual Layer) / DVD+RW: 8x / DVD-RW: 8x / DVD-ROM: 8x / DVD-RAM: 5x / CD-ROM: 24x / CD-R: 24x Maximum Writing Speed DVD+R: 8x (Single Layer), 4x (Double Layer) / DVD-R: 8x (Single Layer), 4x (Dual Layer) / DVD+RW: 8x / DVD-RW: 6x / DVD-RAM: 5x / CD-R: 24x / CD-RW: 16x
Graphics Accelerator	NVIDIA® GeForce® 8400M GT notebook graphics processing unit (GPU)
Total Available Graphics Memory (Max)⁵	383MB
Display	15.4" Wide (WXGA: 1280 x 800) TFT Colour display (Clear Bright High Colour LCD 90)
USB	High Speed USB 2.0 x 3
i.LINK (IEEE 1394)	4pin (S400) x 1
Network (RJ-45) Connector	10Base-T/100Base-TX x 1
Display Output Connector	Analogue RGB, mini D-sub 15pin x 1
S Video In/Out Connector	Output x 1
Headphone	stereo mini jack x 1
Microphone	stereo mini jack x 1
HDMI Connector	Output x 1
Modem	V.92 and V.90 Compliant x 1
Memory Stick Slot	Memory Stick (Standard/Duo Size compatible, MagicGate compatible, Memory Stick PRO compatible, High-speed data transfer compatible) ⁶
SD Memory Card Slot	SD Memory Card ⁷ (SDHC compatible, MMC compatible)
DC IN	x 1
Wireless LAN	• Integrated Wireless LAN IEEE 802.11a/b/g ⁸ • Intel® PRO/Wireless 3945ABG Network Connection • Data rate: maximum 11Mbps (802.11b) / 54Mbps (802.11a/g) ⁹ • Frequency: 5GHz (802.11a), 2.4GHz (802.11b/g)
Bluetooth	Bluetooth standard Ver. 2.0+EDR
Compatible Memory Cards	• Memory Stick (Standard/Duo Size compatible, MagicGate compatible, Memory Stick PRO compatible, High-speed data transfer compatible) • SD Memory Card (SDHC compatible) • Multi Media Card
PC Card Slot	ExpressCard™/34 x 1
Camera	• Effective Pixels: 640 x 480 • Image Device: 1/6" VGA CMOS sensor • Lens: 2 elements in 2 groups F2.8 • Focus distance: f=2.45mm
Audio	• DSD compatible high quality sound chip: "Sound Reality" (Intel® High Definition Audio compatible) • 3D audio (Direct Sound 3D support) • Built-in stereo speakers • Built-in monaural microphone
Keyboard / Input Device	• Approx. 19mm key pitch / 2mm keystroke • 82 keys • Intelligent Touchpad
Battery	Bundled Battery VGP-BPS8 Lithium-ion battery: up to 2.5 hours of use Optional Long Battery VGP-BPL8 Lithium-ion battery: up to 4 hours of use
Life¹⁰	VGP-BPL8 Lithium-ion battery: up to 4 hours of use
Dimensions (W x H x D)	355.8 x 24.9 - 34.5 x 254.4mm
Weight	2.7kg (including the supplied battery)
Included Software	• AV Entertainment: Windows® Media Center, Image Converter 3 • Video Edit/Playback: VAIO Video & Photo Suite 1.1, Adobe® Premiere® Elements 3.0, VAIO Edit Components 6.2, WinDVD for VAIO 8.0 • DVD Creation: Click to DVD 2.6 • Music: SonicStage CP 4.3, SonicStage Mastering Studio 2.3, SonicStage Mastering Studio Audio Filter 2.3 • Still Image/Photo: Windows® Photo Gallery, Adobe® Photoshop® Elements 5.0 (installer) • Home Network: VAIO Media 6.0 • Tool: Roxio Easy Media Creator 9.0, Adobe® Reader® 8, Norton Internet Security™ 2007 ¹¹ • Utilities: VAIO Control Center 2.0, VAIO AV Mode Launcher 1.0, VAIO Camera Utility 2.0, VAIO Camera Capture Utility 2.2 • Support: VAIO Recovery Utility, VAIO Update 3.0, VAIO Hardware Diagnostics 3.3
Supplied Accessories	• AC Adaptor (VGP-AC19V24) • Lithium-ion battery (VGP-BPS8) ¹²
Warranty	One year ¹³

Features and specifications are subject to change without notice.

¹ CPU speed will be reduced under certain operating conditions. ² Intel® Virtualization Technology is not supported on VAIO. ³ If memory modules of the same capacity are installed to both of the two memory module slots, computer will run in dual channel mode and provide better performance. ⁴ Necessary data for recovery (setting back to initial shipment settings) in the hard disk drive consuming approximately 8GB in size is available separately. ⁵ Total Available Graphics Memory refers to the new Windows Vista™ classification of graphics memory, which is the total of Dedicated Video Memory, System Video Memory and Shared System Memory. ⁶ Compatibility confirmed with Sony branded "Memory Stick" media only. ⁷ The copyright protection and high-speed data transfer features of the SD memory card are not supported. ⁸ The maximum communication distance can vary depending on the obstacles or the distance between the communication devices, the radio waves, the operating system or the software being used. ⁹ The communication speed varies depending on the distance between communication devices, existence of obstacles between such devices, the device configuration, the radio conditions, and the software in use. In addition, communication may be cut off depending on the radio conditions. ¹⁰ Estimated battery life (under JETA Battery Run Time Measurement Method ver. 1.0). Actual battery life may vary with different operating conditions and settings. For further details, please visit vaio-online.sony.com ¹¹ Free use of 90 days. Further update will be charged. ¹² This product may only function with a genuine Sony battery designed for this model. ¹³ Warranty conditions may vary by region.

The trademarks, including but not limited to "SONY", "VAIO", "Memory Stick" and "SonicStage" are either trademarks or registered trademarks of Sony Corporation and/or its subsidiaries. Adobe, Adobe Photoshop, Adobe Reader and Adobe Premiere are trademarks of Adobe Systems Incorporated in the United States and/or other countries. Intel, the Intel logo, Centrino and the Centrino logo, Intel Core and Core Inside are trademarks or registered trademarks of Intel Corporation or its subsidiaries in the United States and other countries. Windows, Windows Vista and the Windows logo are trademarks or registered trademarks of Microsoft Corporation in the United States and/or other countries. All other product and brand names may be trademarks or registered trademarks of their respective owners. Whilst information given is true at time of printing, small production changes in the course of our company's policy of improvement through research and design might not necessarily be included in the specifications. E&OE. Actual models may differ slightly in appearance to illustrations provided.

Sony recommends Windows Vista™ Home Premium.

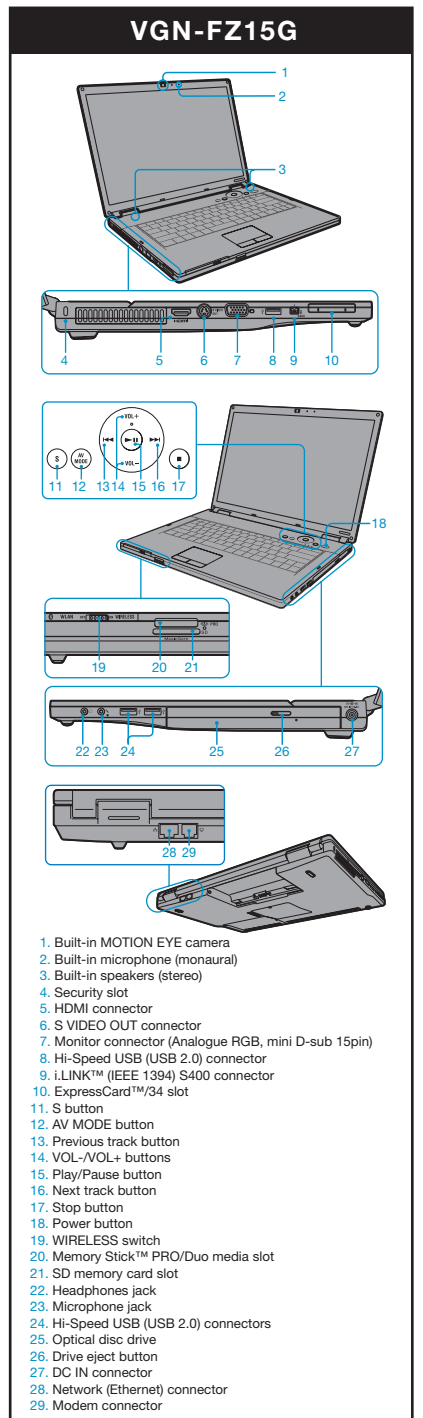

- Built-in MOTION EYE camera
- Built-in microphone (monaural)
- Built-in speakers (stereo)
- Security slot
- HDMI connector
- S VIDEO OUT connector
- Monitor connector (Analogue RGB, mini D-sub 15pin)
- Hi-Speed USB (USB 2.0) connector
- i.LINK™ (IEEE 1394) S400 connector
- ExpressCard™/34 slot
- S button
- AV MODE button
- Previous track button
- VOL-/VOL+ buttons
- Play/Pause button
- Next track button
- Stop button
- Power button
- WIRELESS switch
- Memory Stick™ PRO/Duo media slot
- SD memory card slot
- Headphones jack
- Microphone jack
- Hi-Speed USB (USB 2.0) connectors
- Optical disc drive
- Drive eject button
- DC IN connector
- Network (Ethernet) connector
- Modem connector

Optional Accessories for VGN-FZ15G (availability depends on region)

VGP-BPL8
Lithium-ion Battery (L)

- Rechargeable Battery
- Up to 4 hours of use¹⁰



VGP-SP100

2.1ch Amplified Speakers

- Unparalleled multimedia experience
- Easy connectivity via USB 2.0
- 1.2W Subwoofer plus bass balance



VGP-CP12
Carrying Pouch

- Slim, lightweight pouch sized for VAIO FZ
- Handy zip fastener and stylish VAIO Logo
- Polyurethane for scratch and dust protection



VGP-MBC20
Black (B), Gray (H)
Carrying Bag

- Smart protection with style
- Luxurious, abundant space
- Retractable handle for portable ease



VGP-BMS33
Silver (S), Black (B)

Bluetooth® Laser Mouse

- Smart wireless mouse for mobile use
- Highly accurate laser sensor
- Innovative PTFE sole for precise operation
- Sensor resolution: 800 dots per inch



VGP-UMS55
Silver (S), Black (B)
USB Laser mouse

- Ergonomic design naturally fits your hand
- Highly accurate laser sensor
- Innovative PTFE sole for precise operation
- Sensor resolution: 800 dots per inch



vaio-online.sony.com





Experience the joy of AV entertainment

Enjoy user-friendly computing on the VAIO FZ15G. It brings movies to life on Sony's latest 15.4" wide Clear Bright High Colour LCD 90, which boasts the purest colour reproduction of any VAIO. The simply elegant design, with black and silver finish and convenient AV Control Buttons, looks great wherever you take it. Moreover, performance reaches new heights thanks to cutting-edge Intel® Centrino™ Duo Processor Technology. Bring the pleasures of convenient mobile computing to your home today!



✦ Main features

Beautiful viewing: Clear Bright High Colour LCD 90	Built-in Camera: MOTION EYE	Network freedom: Wireless LAN 802.11a/b/g Bluetooth®	High-durability: Magnesium Body	Handy Presentation: Plug & Display	Direct Media Access: Memory Stick Slot/ SD Memory Card Slot	High-quality sound: Sound Reality Audio Chip
Simple entertainment access: AV Control Buttons	Connect to TV: HDMI Connector, S-Video Out Connector	Handy home use: 2.7kg	Battery stamina: Up to 2.5 hours			
✦ Basic specifications						
Intel® Core™2 Duo Processor T7100 (1.80GHz)	Genuine Windows Vista™ Home Premium	15.4" WXGA display 1280 x 800	NVIDIA® GeForce® 8400M GT GPU	DVD±RW/±R DL/RAM Drive	Memory 1GB (Max 2GB)	Hard Disk Drive 120GB

Colour your world with high definition

Savor the stunning image quality of Sony's latest 15.4" wide Clear Bright High Colour LCD 90 (WXGA: 1280 x 800), which reproduces remarkably accurate colour thanks to BRAVIA backlight technology. It's perfect for playing DVD movies you shot with your HDV Handycam and edited on your VAIO FZ15G. You can also play them on connected large-screen TVs via HDMI cable. Sound Reality adds to the excitement with superior audio quality, and handy AV Control Buttons simplify AV operation. You can also video chat using the built-in MOTION EYE camera and microphone, as well as wirelessly communicate with Bluetooth®. Let the brilliant VAIO FZ15G enhance your mobile lifestyle.

The beauty of refined craftsmanship

The new VAIO FZ15G is elegantly engineered with subtle refinements that convey excellent taste. Beautifully simple, its silver and black colour scheme complements any wardrobe and environment, whether at home or in the office. Lightweight for mobility, its dimensions are compact yet contain leading-edge technology like a wide 15.4" LCD and flush, built-in MOTION EYE camera lens. Main body panels are constructed of Die-cast magnesium, a material prized everywhere for its remarkable beauty and rigidity. It's a sophisticated, refreshing design that never goes out of style and makes you look your best wherever you go.



Leap forward with leading performance

A genuine high-tech advantage is yours with the new VAIO FZ15G — the latest, cutting-edge Intel® Centrino® Duo Processor Technology. Relish the exceptional performance of Intel® Core™2 Duo Processor T7100 (1.80GHz), next-generation Mobile Intel® PM965 Express Chipset, 800MHz Front Side Bus (FSB), and Intel® PRO/Wireless 3945ABG Network Connection. Thanks to Windows Vista™ Home Premium, the latest operating system, you'll enjoy intuitive operation and responsive search functions. Powerful NVIDIA® GeForce® 8400M GT GPU adds to the pleasure of HD movie editing and gameplay with accelerated graphics. All this exceptional performance is supported by a large-capacity 120GB HDD (Serial ATA, 5400rpm) and 1GB of DDR2 SDRAM 667MHz main memory. Enjoy your PC lifestyle with the VAIO FZ15G.

VIDEO & PHOTOS

- Click to DVD**
Create video and photo DVDs on DVD±RW/±R DL or DVD-RAM discs in one click, with 5.1 surround sound.
- VAIO Video & Photo Suite**
Import and export a wide range of AV files simply and smoothly for playback and editing.
- Adobe® Premiere® Elements**
Enjoy advanced editing of videos, photos, and music with this renowned software.
- Adobe® Photoshop® Elements**
Add a personal touch to your prized still images and present them effectively to your friends.
- Roxio Easy Media Creator**
Back up audio, image, and data files on CDs and DVDs with ease for personal archiving.

WinDVD for VAIO / Windows® Photo Gallery

MUSIC

- SonicStage CP**
Import the music you like from various sources, create your own playlists and send your music to a Walkman.*
- SonicStage Mastering Studio**
Convert analogue music to digitally enhanced audio** with high-quality effector modules.
- SonicStage Mastering Studio Audio Filter**
Enhance any audio content played on VAIO laptop PCs and enjoy it with excellent headphone presets.

SUPPORT

- VAIO Update**
Alerting you to important changes via Internet that appear as reminder balloons on your desktop.***
- Norton Internet Security™ 2007**
Highly effective monitoring for viruses and spyware helps keep computing secure.****
- VAIO Recovery Utility / VAIO Hardware Diagnostics

* Availability depends on region.
** Roland EDIROL AUDIO capture UA-25* or UA-101* USB audio interface device required.
*** Internet connection required for use.
**** Free use of 90 days. Further update will be charged.
Note: Any copying or reproduction of copyrighted material may amount to copyright infringement. Song titles, names of artists and other information shown in the SonicStage CP screen capture are provided for illustrative purposes only.

