

Sony recommends Windows Vista™ Home Premium.

## Specifications

<b>Model</b>	VGC-LA38G
<b>Processor</b>	Intel® Core™2 Duo Processor T5600 (1.83 GHz) <sup>1,2</sup>
<b>Operating System</b>	Genuine Windows Vista™ Home Premium (English version) with Traditional Chinese Language Pack
<b>Chipset</b>	Intel® 945PM Express Chipset
<b>Processor System Bus</b>	667MHz
<b>Memory Bus</b>	667MHz
<b>Cache Memory</b>	2MB Advanced Smart Cache
<b>Main Memory</b>	1GB DDR2 SDRAM <sup>3</sup> (upgradeable up to 2 GB) 2 SO-DIMM slots (The pre-installed memory module uses one)
<b>Hard Disk</b>	120GB (HDD Recovery Storage: 7GB <sup>4</sup> , C: Remain) Serial ATA, 5400 rpm
<b>Optical Drive<sup>5</sup></b>	DVD±RW±R DL/RAM Drive Maximum reading speed: DVD-ROM: 8x / DVD-R, DVD-R, DVD+R DL, DVD-R DL, DVD+RW, DVD-RW: 6x / DVD-RAM: 5x / CD-R, CD-ROM, CD-RW: 24x Maximum writing speed: DVD+R, DVD-R: 8x / DVD+RW, DVD-RW: 4x / DVD-R DL: 2.4x / DVD-R DL: 2x / DVD-RAM: 5x / CD-R: 24x / CD-RW: 16x
<b>Graphics Accelerator</b>	NVIDIA® GeForce® Go 7400 notebook graphics processing unit (GPU)
<b>Total Available Graphics Memory (Max)<sup>6</sup></b>	319MB
<b>Display</b>	15.4" Wide (WXGA: 1280 x 800) TFT colour display (Clear Bright LCD: Single Lamp, Standard View)
<b>Interfaces</b>	• USB 2.0 x 4 • i.LINK (IEEE 1394) S400 (4pin) • Network (RJ-45) connector (100BASE-TX/10BASE-T) • Headphone jack (stereo mini) • Line-In jack (stereo mini) • Microphone jack (stereo mini) • Modular (RJ-11) connector • Memory Stick slot <sup>7</sup> (Standard/Duo Size compatible, MagicGate compatible, Memory Stick PRO compatible, High-speed data transfer compatible) • SD Memory Card slot <sup>8</sup> (MMC compatible)
<b>Wireless LAN</b>	• Integrated Wireless LAN IEEE 802.11b/802.11g <sup>9</sup> • Data rate: maximum 11Mbps (802.11b)/54 Mbps (802.11g) <sup>10</sup> • Frequency: 2.4 GHz (802.11b/g)
<b>Modem</b>	V.92 and V.90 Compliant
<b>PC Card Slot</b>	ExpressCard™/54 x 1, Type I/II x 1
<b>Camera</b>	Effective Pixels: 640x480 • Image Device: 1/6", VGA CMOS • Lens: 2 elements in 2 groups, F2.8 (Fixed) • Focus distance: f=2.45mm
<b>Audio</b>	DSD compatible high quality sound chip: "Sound Reality" (Intel® High Definition Audio compatible) • 3D audio (Direct Sound 3D support) • Built-in stereo speakers • Built-in monaural microphone
<b>Keyboard / Input Device</b>	Approx. 18mm key pitch / 2.3 mm keystroke • 82 keys • Intelligent Touchpad
<b>Battery</b>	VGP-BPS2B <sup>11</sup> Lithium-ion battery: up to 2.0 hours of use <sup>12</sup>
<b>Dimensions (W x H x D)</b>	470.2mm x 289.9mm x 141.7mm (Under minimal tilt with folded keyboard) 470.2mm x 257.9mm x 383.5mm (Under maximal tilt with opened keyboard)
<b>Weight</b>	4.5kg (including the supplied battery)
<b>Included Software</b>	• <b>AV Entertainment:</b> Windows® Media Center • <b>Video Edit/Playback:</b> DVgate Plus 2.3, VAIO Video & Photo Utility 1.0, Adobe® Premiere® Elements 3.0 (Installer), VAIO Edit Components 6.1 (Installer), WinDVD for VAIO 8.0 • <b>DVD Creation:</b> Click to DVD 2.6 • <b>Music:</b> SoundFLOW, SonicStage CP 4.2, SonicStage Mastering Studio 2.3, SonicStage Mastering Studio Audio Filter 2.3 • <b>Still Image/Photo:</b> Windows® Photo Gallery, Adobe® Photoshop® Elements 5.0 (Installer) • <b>Home Network:</b> VAIO Media 6.0 • <b>Tool:</b> Roxio Easy Media Creator 9.0 (Installer), Adobe® Reader® 7, Norton Internet Security™ 2007 • <b>Utilities:</b> VAIO Control Center 2.0, VAIO Camera Utility 2.0 • <b>Support:</b> VAIO Recovery Utility, VAIO Update 3.0
<b>Supplied Accessories</b>	• AC adapter (VGP-AC19V12) • Lithium-ion battery (VGP-BPS2B) • 8cm Disc Adapter
<b>Warranty</b>	One year <sup>13</sup>

Features and specifications are subject to change without notice.

<sup>1</sup> CPU speed will be reduced under certain operating conditions. <sup>2</sup> Intel® Virtualization Technology is not supported on VAIO. <sup>3</sup> If memory modules of the same capacity are installed to both of the two memory slots, computer will run in dual channel mode and provide better performance. <sup>4</sup> Necessary data for recovery (setting back to initial shipment settings) in the hard disk drive consuming approximately 7GB in size is available separately. <sup>5</sup> This optical drive is not capable of writing data onto an 8cm disc. Please use the bundled 8cm disc adapter for reading data of an 8cm disc. <sup>6</sup> Total Available Graphics Memory refers to the new Windows Vista classification of graphics memory, which is the total of Dedicated Video Memory, System Video Memory and Shared System Memory. <sup>7</sup> Compatibility confirmed with Sony branded "Memory Stick" media only. <sup>8</sup> The copyright protection and high-speed data transfer features of the SD Memory Card are not supported. <sup>9</sup> The maximum communication distance can vary depending on the obstacles or the distance between the communication devices, the radio waves, the operating system or the software being used. <sup>10</sup> The communication speed varies depending on the distance between communication devices, existence of obstacles between such devices, the device configuration, the radio conditions, and the software in use. In addition, communication may be cut off depending on the radio conditions. <sup>11</sup> This product may only function with a genuine Sony battery designed for this model. <sup>12</sup> Estimated battery life (under JEITA Battery Run Time Measurement Method (ver.1.0)). <sup>13</sup> Warranty conditions may vary by region.

The trademarks, including but not limited to "SONY", "VAIO", "Memory Stick" and "SonicStage" are either trademarks or registered trademarks of Sony Corporation and/or its subsidiaries. Adobe, Adobe Photoshop, Adobe Reader and Adobe Premiere are trademarks of Adobe Systems Incorporated in the United States and/or other countries. Intel, the Intel logo, Centrino and the Centrino logo, Intel Core and Core Inside, are trademarks or registered trademarks of Intel Corporation or its subsidiaries in the United States and other countries. Windows, Windows Vista and the Windows logo are trademarks or registered trademarks of Microsoft Corporation in the United States and/or other countries. All other product and brand names may be trademarks or registered trademarks of their respective owners. Whilst information given is true at time of printing, small production changes in the course of our company's policy of improvement through research and design might not necessarily be included in the specifications. E&OE. Actual models may differ slightly in appearance to illustrations provided.

## Optional Accessories for the VGC-LA38G (availability depends on region)

### VGP-BPS2C

#### Lithium-ion Battery

- Identical to the supplied rechargeable battery
- Up to 2.0 hours of use<sup>12</sup>



### VGP-UMS55

#### Silver(S), Black(B)

#### USB Laser Mouse

- Smart wireless mouse for mobile use
- Highly accurate laser sensor
- Innovative PTFE sole for precise operation
- Sensor resolution: 800 dots per inch



### VGP-CG100

#### PC Cleaning Kit

- PC/LCD cleaning with microfibre cloth
- Goat-fur brush for meticulous dusting of PC/keyboard
- Integrated case includes handbook PC/keyboard



### VGP-UMS20

#### Silver(S), Black(B)

#### USB Optical Mouse

- Innovative PTFE sole for precise operation
- Sensor resolution: 800 dots per inch
- Cable length: 80cm

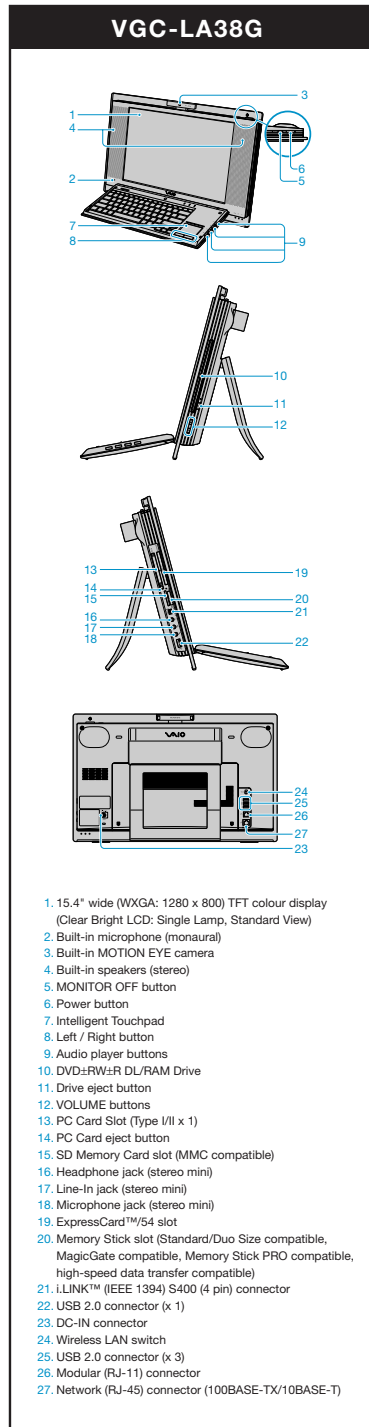

- 15.4" wide (WXGA: 1280 x 800) TFT colour display (Clear Bright LCD: Single Lamp, Standard View)
- Built-in microphone (monaural)
- Built-in MOTION EYE camera
- Built-in speakers (stereo)
- MONITOR OFF button
- Power button
- Intelligent Touchpad
- Left / Right button
- Audio player buttons
- DVD±RW±R DL/RAM Drive
- Drive eject button
- VOLUME buttons
- PC Card Slot (Type I/II x 1)
- PC Card eject button
- SD Memory Card slot (MMC compatible)
- Headphone jack (stereo mini)
- Line-In jack (stereo mini)
- Microphone jack (stereo mini)
- ExpressCard™/54 slot
- Memory Stick slot (Standard/Duo Size compatible, MagicGate compatible, Memory Stick PRO compatible, high-speed data transfer compatible)
- i.LINK™ (IEEE 1394) S400 (4 pin) connector
- USB 2.0 connector (x 1)
- DC-IN connector
- Wireless LAN switch
- USB 2.0 connector (x 3)
- Modular (RJ-11) connector
- Network (RJ-45) connector (100BASE-TX/10BASE-T)

# SONY



Intel® Core™ 2 Duo Processor

# VAIO L

# VGC-LA38G



## Debut of a brand-new form: The Panel PC

vaio-online.sony.com



like.no.other

VAIO  
no more bounds

# VGC-LA38G

## Streamline your lifestyle with Panel PC, a whole new idea in PC design



Just when you think you know what a PC is supposed to look like, Sony turns conventional thinking on its head. VAIO L is unconventional, unprecedented, and ready to streamline your lifestyle. The secret behind it is a transparent board that serves as the chassis and as the frame that highlights the new design. Its design melds with any interior décor, with an integrated carrying handle and wireless LAN capability that let you use it in any room. The latest Windows Vista<sup>a</sup> operating system assures advanced functionality. And when not being used as a computer, it can live up any location you place it as an audio player.



### Sleek Style

It's not a desktop, nor is it a notebook – it takes the benefits of both and fits them neatly into a sleek, streamlined profile.

<b>Transparent Frame</b> See-through frame with high-visibility LED lamps accentuate the design that fits any room.		<b>Retractable Keyboard</b> Complete with built-in touch pad, the retractable keyboard makes it easy to carry VAIO L.		<b>Slot-in Drive</b> Tray-less to match VAIO L's streamlined design.* <small>*8cm disc adaptor supplied</small>
	<b>Built-in Folding Stand</b> With one-finger ease, you can adjust the integrated stand to the optimum angle from 12° to 30°.		<b>Integrated Carrying Handle</b> Unobtrusively design-integrated, this handle makes it easy to carry VAIO L to any room.	

#### Main features

Slim body: approx. 14cm depth*	Built-in Camera MOTION EYE	Beautiful viewing: Clear Bright LCD	DVD video recording: Click to DVD	Content sharing: Memory Stick slot/SD card slot	Exclusive music software: SoundFLOW
Powerful speakers: 3W + 3W output	High quality sound: Sound Reality Audio Chip	Built-in rechargeable battery: Up to 2 hours	Easy to carry: Weight 4.5kg	Monitor-off button for power saving	Network freedom: Wireless LAN 802.11b/g

\*at minimum tilt, keyboard closed

### Show It Off

Just playing your music is not enough. VAIO L makes sure you can show it off while you keep your audience entertained. Exclusive music software SoundFLOW automatically launches for music playback when the keyboard is closed, while special audio player buttons offer easy control. Selectable wallpapers let you match it perfectly with your room or your mood. You'll be amazed at the high quality sound, too. Make music an integral part of your life, without taking up all your space.

#### Selectable wallpapers



#### Various utility functions

- Clock / Wakeup Timer / Sleep Timer
- Play Music / Shuffle Mode
- Jacket Photo / Music Title
- Calendar

### Move It Around

VAIO L offers a thin profile that's approximately 14 cm\* deep and has an integrated carrying handle to make it easy to carry to another room. And with built-in battery operation, a retractable wireless keyboard as well as wireless LAN capability, you'll probably be using it in just about any room.

\*at minimum tilt, keyboard closed

**Radically new base chassis design and materials**

The base chassis is made of a transparent polycarbonate material that offers superior durability and fire resistance characteristics. And what's even more amazing is that the chassis is also the transparent frame that surrounds the LCD monitor and gives VAIO L its uniquely elegant and stylish look.

#### Basic specifications

Intel® Core™2 Duo Processor T5600 (1.83GHz)	Genuine Windows Vista <sup>a</sup> Home Premium	15.4" WXGA 1280 x 800 LCD	NVIDIA GeForce Go 7400 GPU
DVD±RW/±R DL/RAM Drive	1GB (DDR2) Main Memory (Upgradeable up to 2GB)	120GB Hard Disk Drive (Serial ATA, 5400rpm)	

### DVD CREATION

With Click to DVD, you're only a click away from creating your own photo, movie + photo, or video DVD on a DVD-RAM disc. You can also create 5.1 surround sound DVDs. Moreover, Roxio Easy Media Creator 9 is a powerful digital media tool that lets you back up data, copy CD/DVDs, create music CDs, edit stills or video, and perform DVD authoring.

Click to DVD

Roxio Easy Media Creator 9

### VIDEO & PHOTOS

VAIO Video & Photo Utility makes it easier than ever to import and export many kinds of AV files. VAIO Content Importer simplifies the import of videos and photos from various sources, including Handycam\*, Cyber-shot\*, and DLNA server. You can then edit your video footage with Adobe Premiere Elements and your still images with Adobe Photoshop Elements. After editing, data can easily be burned on a DVD or exported to a Memory Stick with VAIO Content Exporter, letting you fully enjoy your digital lifestyle.

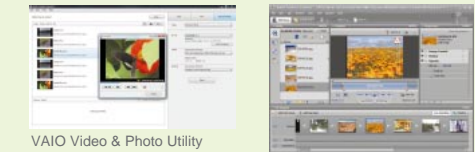

VAIO Video & Photo Utility

Adobe Premiere Elements



Adobe Photoshop Elements

### MUSIC

Import music from the Net or CDs with SonicStage CP. Then transfer it to a Walkman\* or burn your own original CDs. SonicStage Mastering Studio lets you import analogue music (Roland EDIROL AUDIO capture UA-25\* or UA-101\* USB audio interface device required) and edit it with high-quality effector modules before recording on a CD. SonicStage Mastering Studio Audio Filter can enhance any sound played on VAIO and provides excellent headphone presets.

SonicStage CP

SonicStage Mastering Studio

SonicStage Mastering Studio Audio Filter



\* Availability depends on region. Note: Any copying or reproduction of copyrighted material may amount to copyright infringement. Song titles, names of artists and other information shown in the SonicStage screen capture are provided for illustrative purposes only.